

VOICE active



VOICEPHONE USER GUIDE

CONTENTS

3. VoicePhone Features
4. Installation
5. Installation cont....
6. Headset features
7. Troubleshooting
8. Warranty

FEATURES

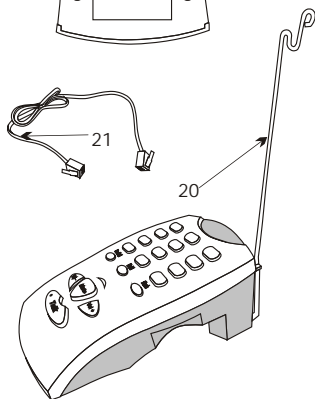
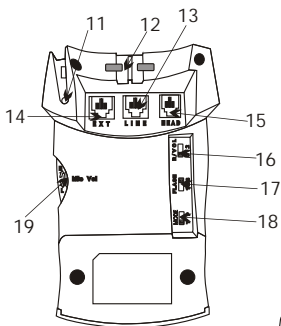
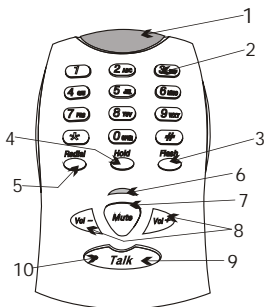

1. Ring flasher
2. Dial / key pad
3. Redial key
4. Hold key
5. Flash key (recall / R function)
6. Mic. Mute key
7. Mute LED indicator
8. Receiver volume control
9. Talk key (hook switch)
10. Talk LED indicator
11. Headset stand mounting
12. Line cord restraint
13. Line jack
14. Extension line jack
15. Mic / transmit level control
16. Headset jack
17. Ringer volume selector
18. Flash timing selector
19. Tone / pulse dial selector
20. Headset stand
21. Cord for extension phone

INSTALLATION

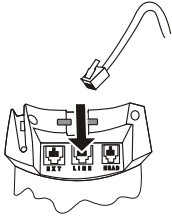

1. Plug the line cord into the line jack on the VoicePhone and into your telephone wall socket.

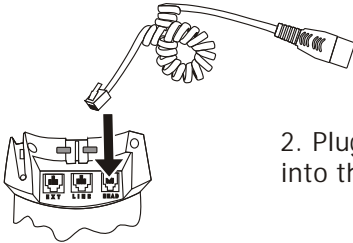

2. Plug the headset D cable into the headset jack.

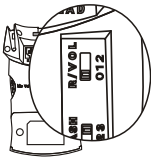

3. Select your desired ringer level; 0 = Silent, 1 = Low and 2 = High

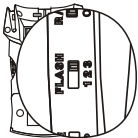

4. Set the flash timing to match your phone service.
1 = 100ms, 2 = 300ms and
3 = 600ms

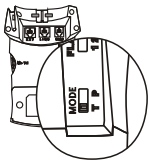

5. Select tone or pulse dialling
(Tone set as standard in UK)

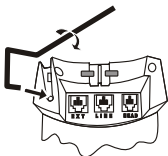

6. Fit the headset stand.
Simply clip into place.

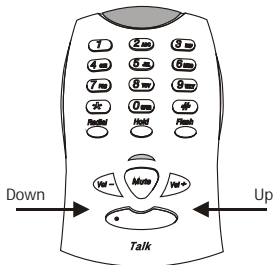

7. Adjust the receiver volume to suit. The adjustment is in incremental steps, each press of the button is one step. There are 32 steps from minimum to maximum volume and vice versa.

8. If required, connect your existing telephone via the extension lead and jack. Please note that the VoicePhone ringer will override the extension ringer.

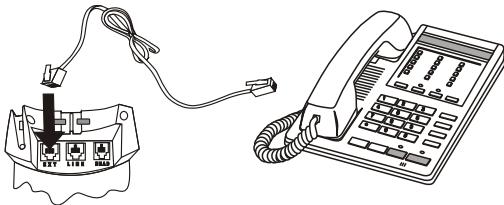

HEADSET

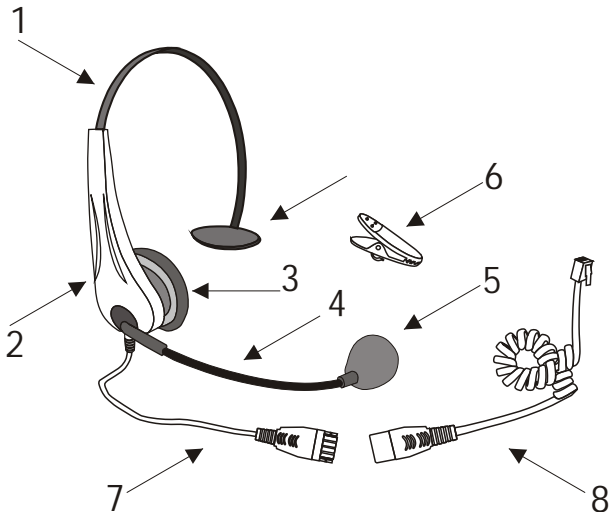

1. Adjustable headband with coded "T" Piece
2. Main headset body*, colour coded to VoicePhone
3. Receiver fitted with either leatherette or foam ear cushion (both supplied)
4. Flexible microphone boom
5. Microphone with foam windshield fitted
6. Clothing clip, to secure the headset cable to; eg your lapel
7. Headset QD cable
8. D Cable (QD Cable) connects to the headset jack

TROUBLESHOOTING

No Dial tone:

Make sure that your connections are good, are all the modular plugs “clicked” in correctly.

Make sure that you have pressed the “talk” button and that the talk indicator is lit.

Cannot dial out:

Make sure that the Tone/pulse is setting is correct.

The talk button must be pressed and dial tone heard, before dialling.

Callers voice is too loud/Quiet:

Adjust the receive volume control either up or down to suit. The adjustment is in incremental steps, each press of the button is one step. There are 32 steps from minimum to maximum volume and vice versa.

Callers can't hear me, but I can hear them:

Make sure that your headset microphone is positioned correctly it should be approximately 25mm from the front of your mouth.

Adjust the mic gain control to the desired level, make a test call to a friend or colleague if necessary.

Check that the mute switch isn't depressed the mute indicator will be lit if the microphone is muted.

WARRANTY

All Voice Active headset products are covered by a two year warranty for electronic/electrical and/or manufacturing defects.

For warranty repair please return the faulty product to:

Voice Active Maintenance
Station Yard
Thame
Oxfordshire
OX9 3UH
United Kingdom

Please enclose your name and address, proof of purchase and a description of the fault.

For further information, please contact your headset supplier.



www.voiceactive.com